

## New-generation HT DESI-MS technology for drug discovery

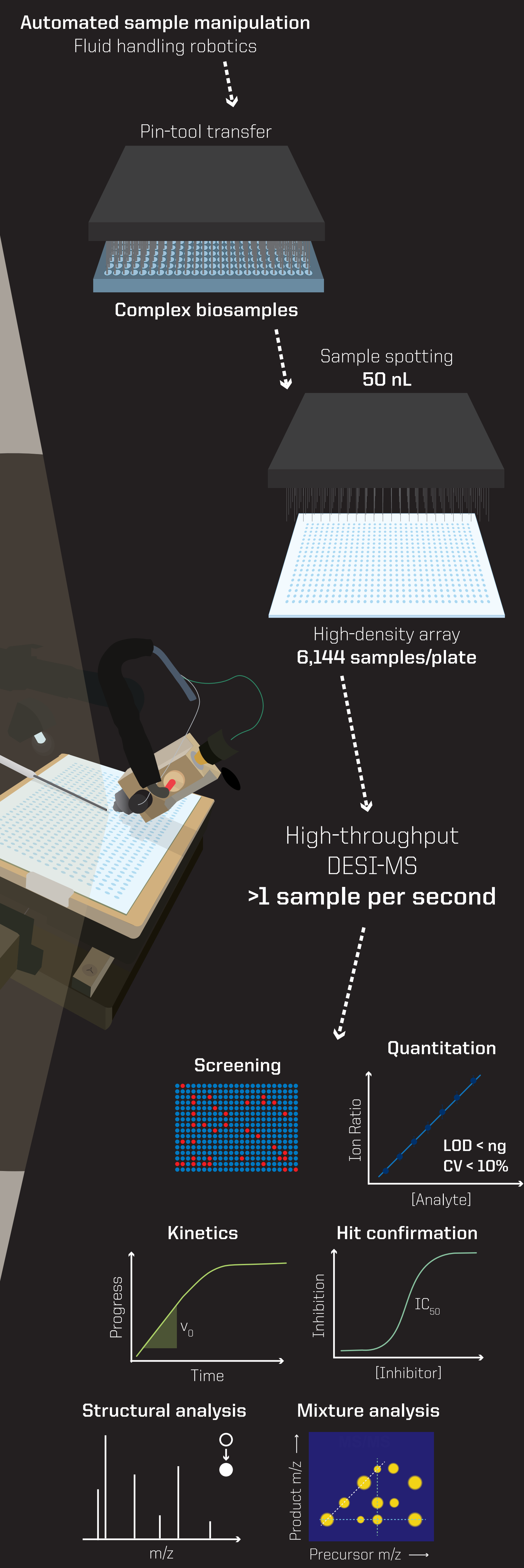

# High-Throughput Bioanalysis Using an Automated Ambient Mass Spectrometry Platform

Nicolás M. Morato, Veronica Feng, Samadhi Kulathunga, Beinan Yang, Bridget Kaiser, Jian Yang, L. Edwin Gonzalez, Alexis R. Toney, Kenneth L. Virgin, Christina R. Ferreira, My Phuong T. Le, Carson B. Roberts, Elizabeth I. Parkinson, Timothy L. Ratliff, Andrew D. Mesecar, and R. Graham Cooks

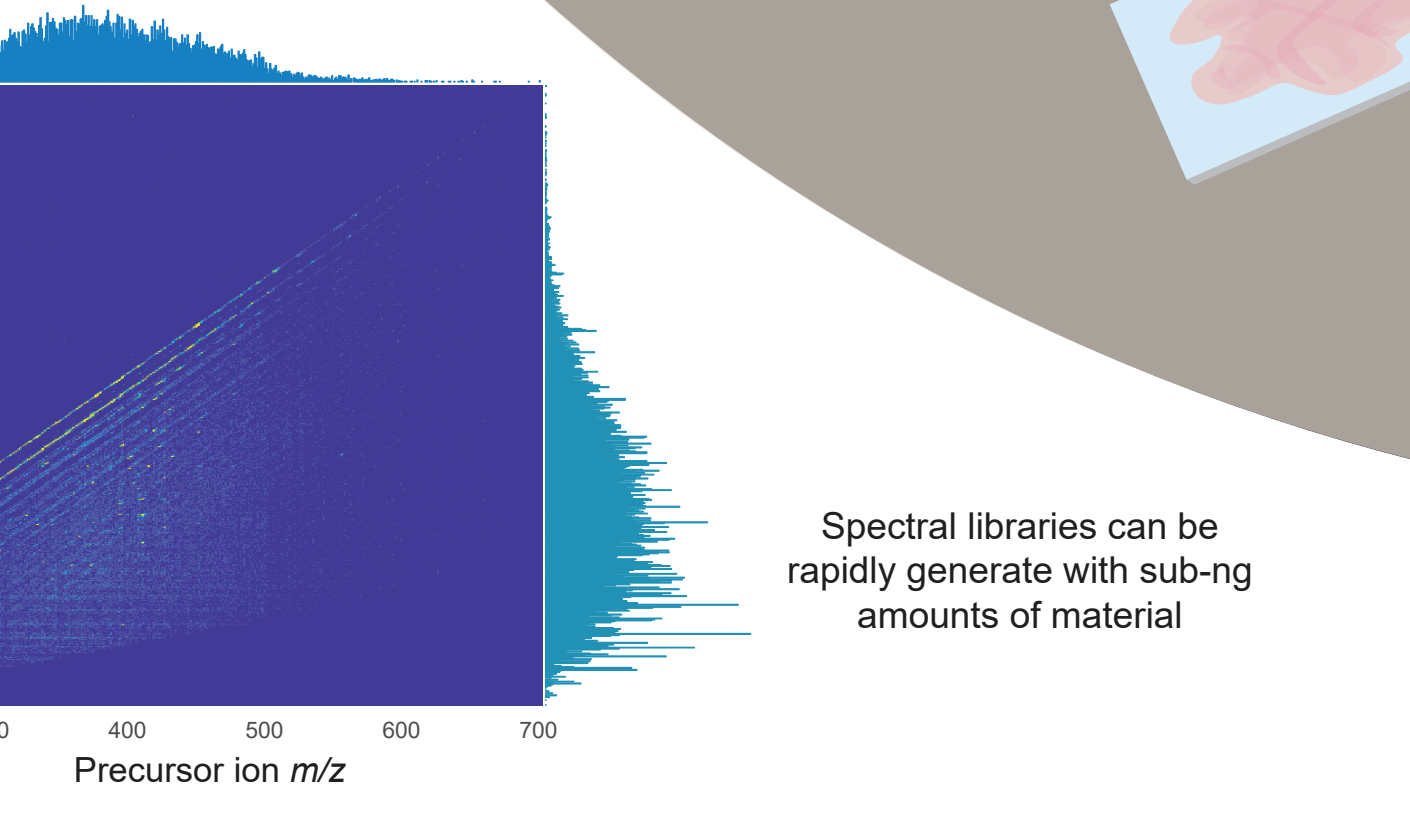
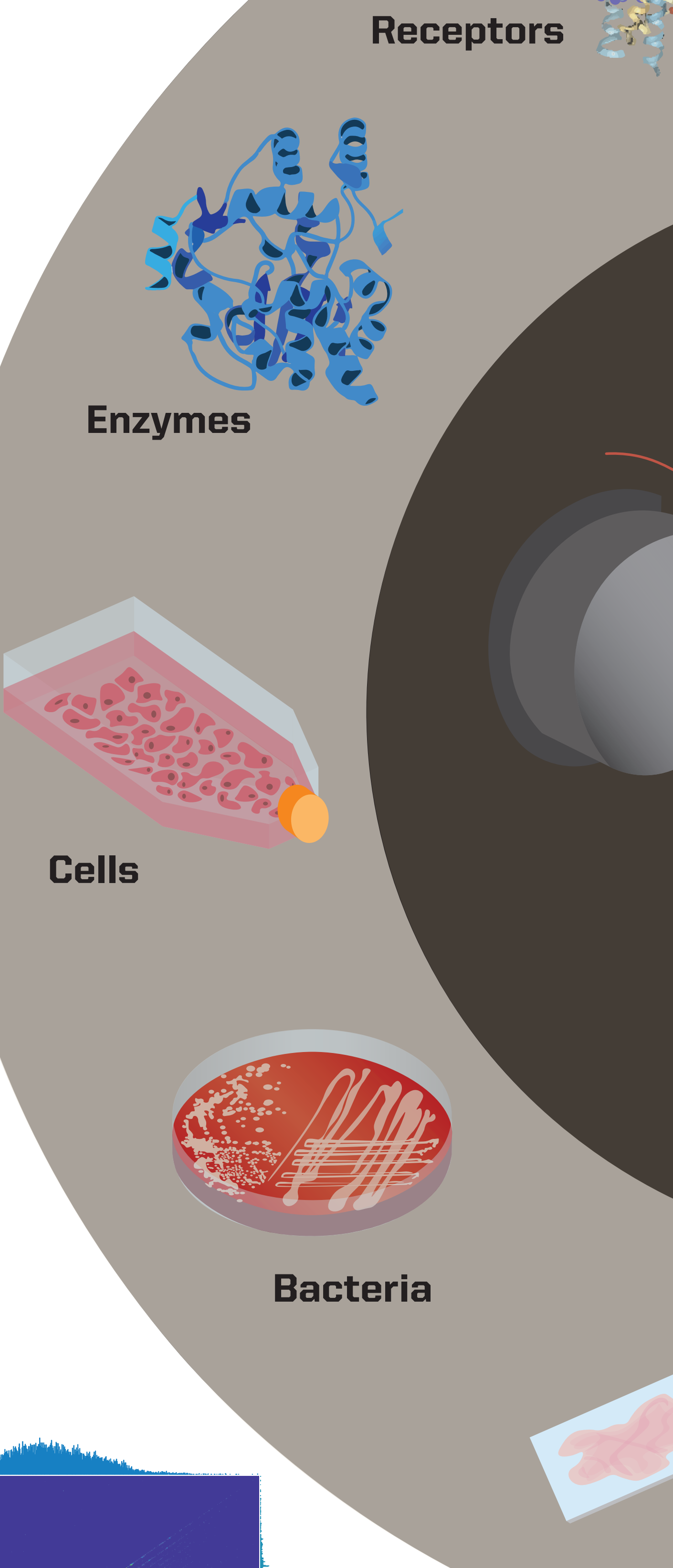
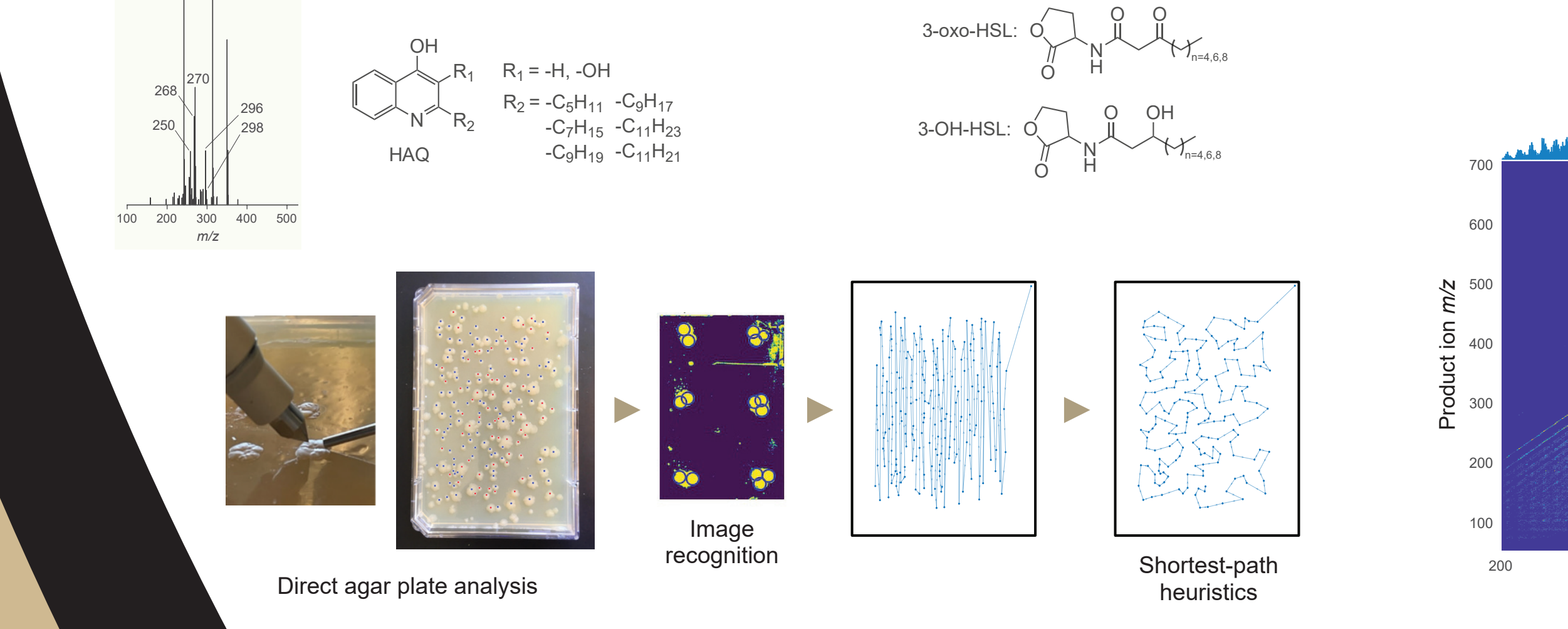
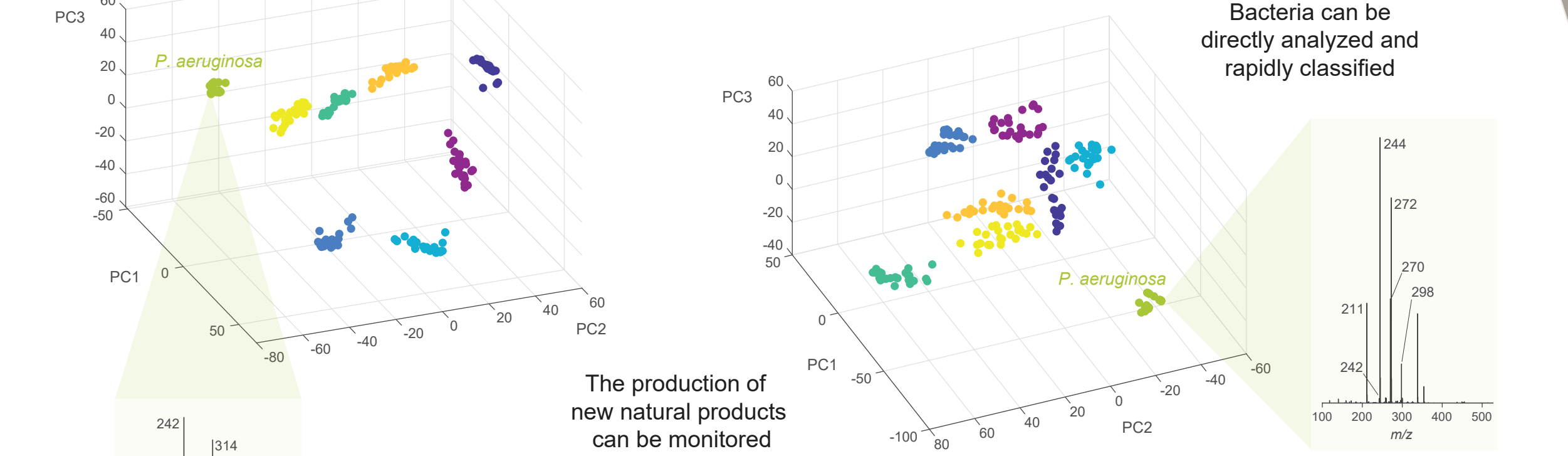
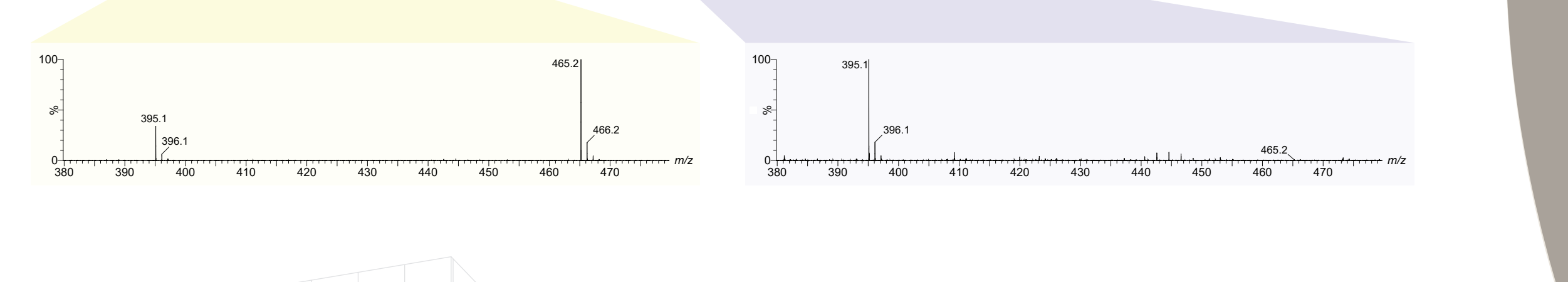
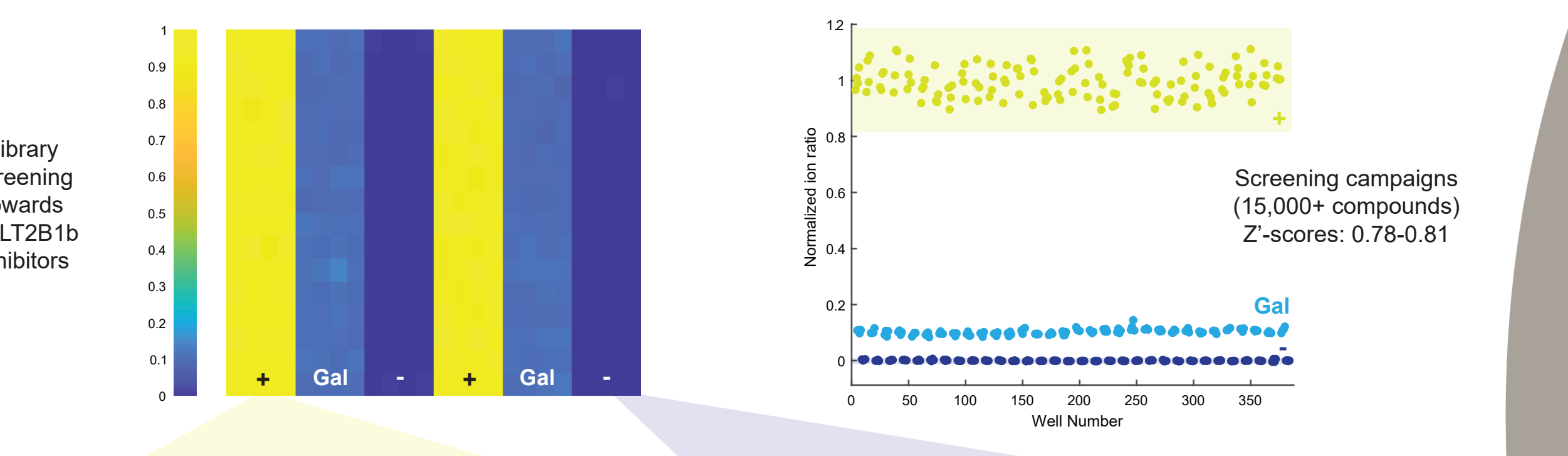
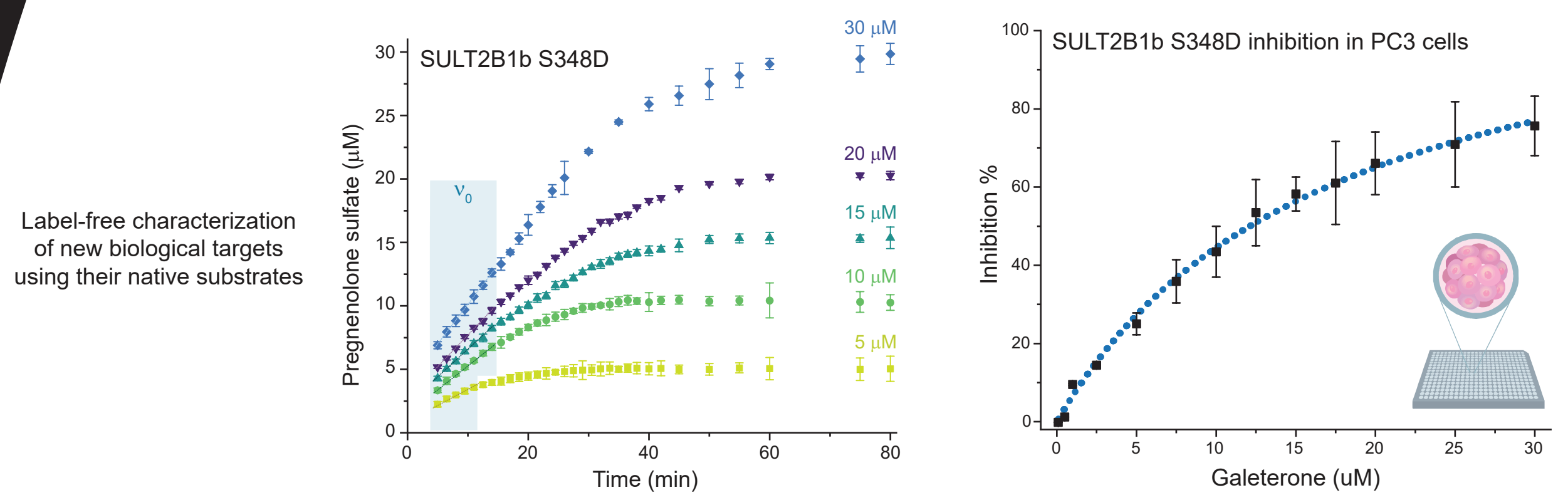
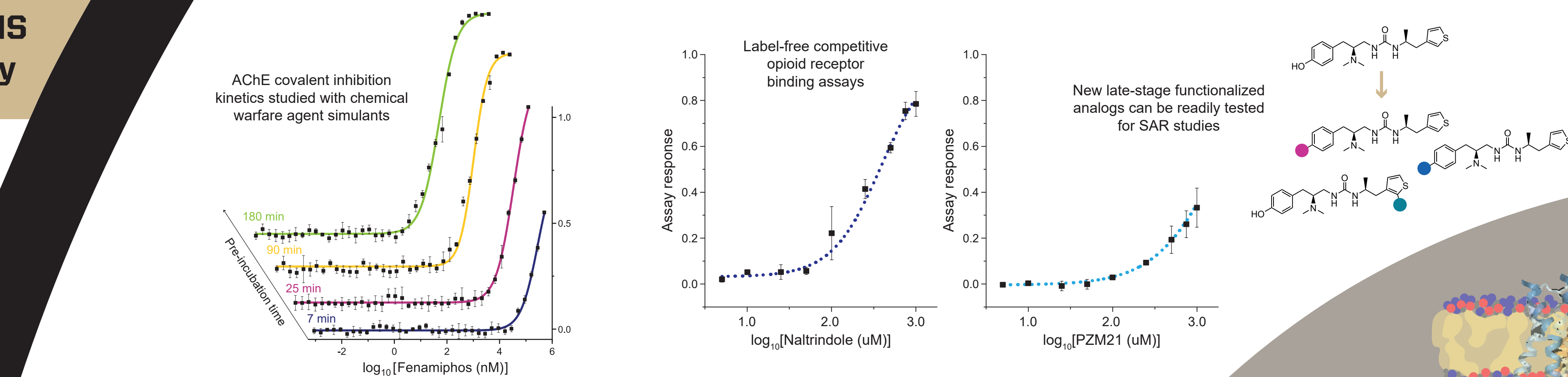
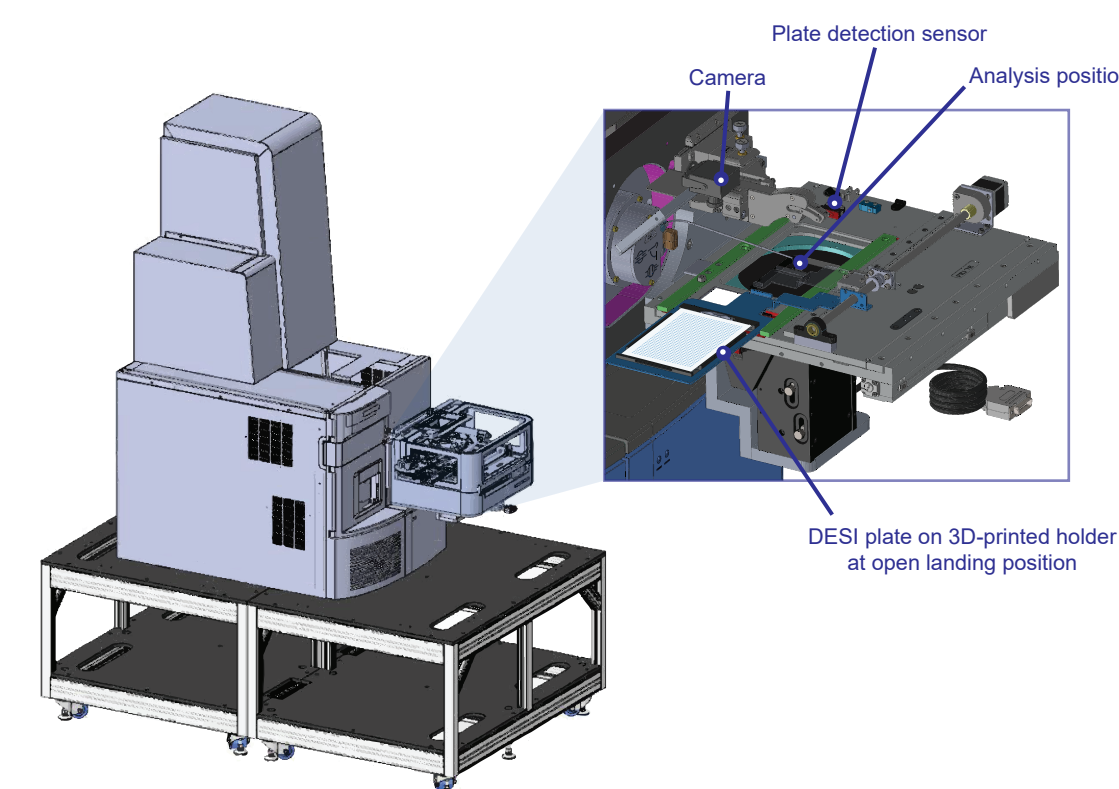
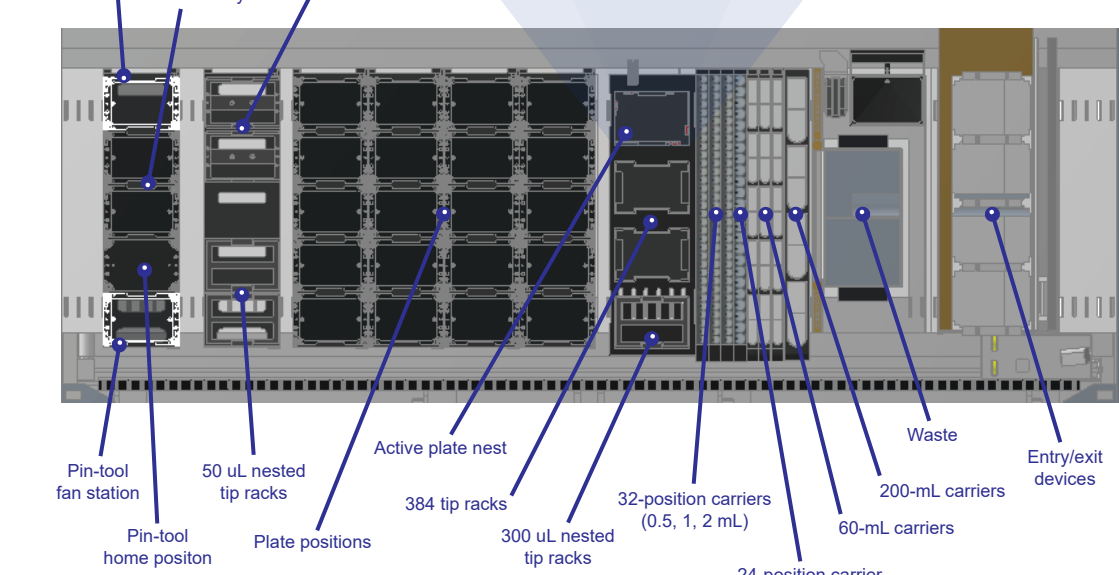
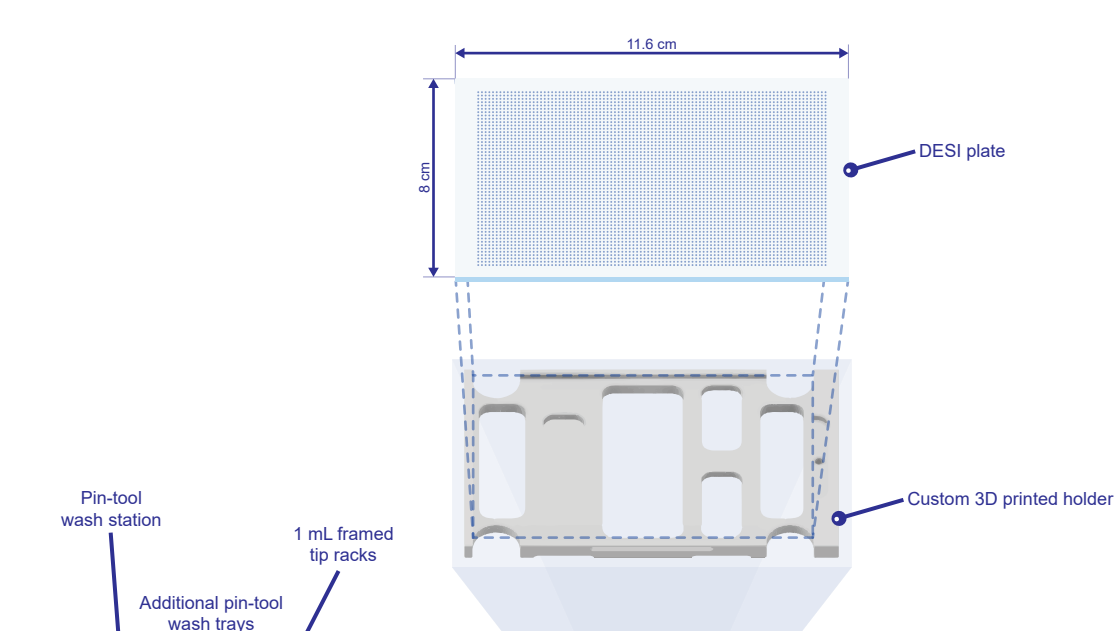
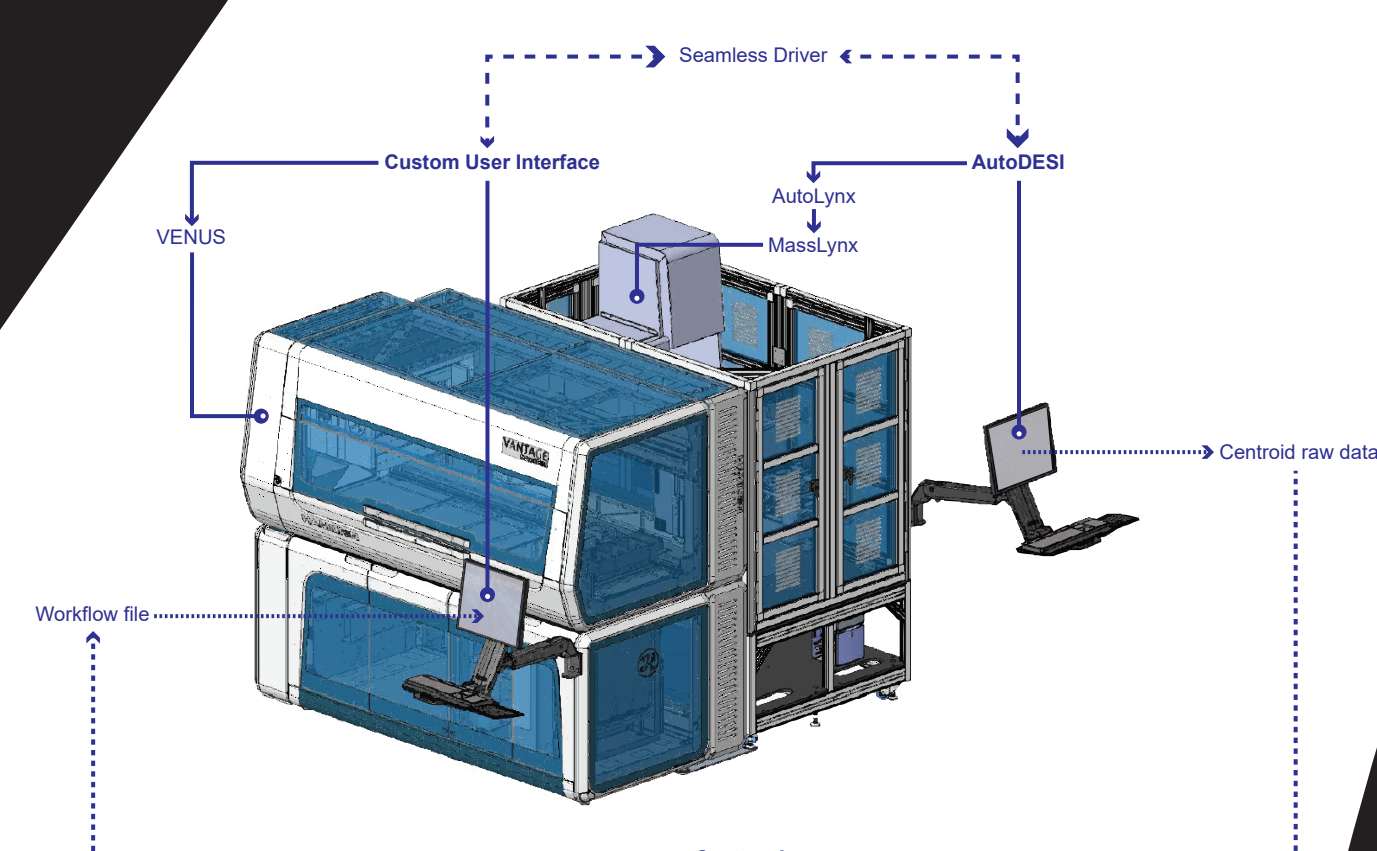